



Backend of the Fuel Cycle

Paul Murray

December 2012



New Nuclear Fuel

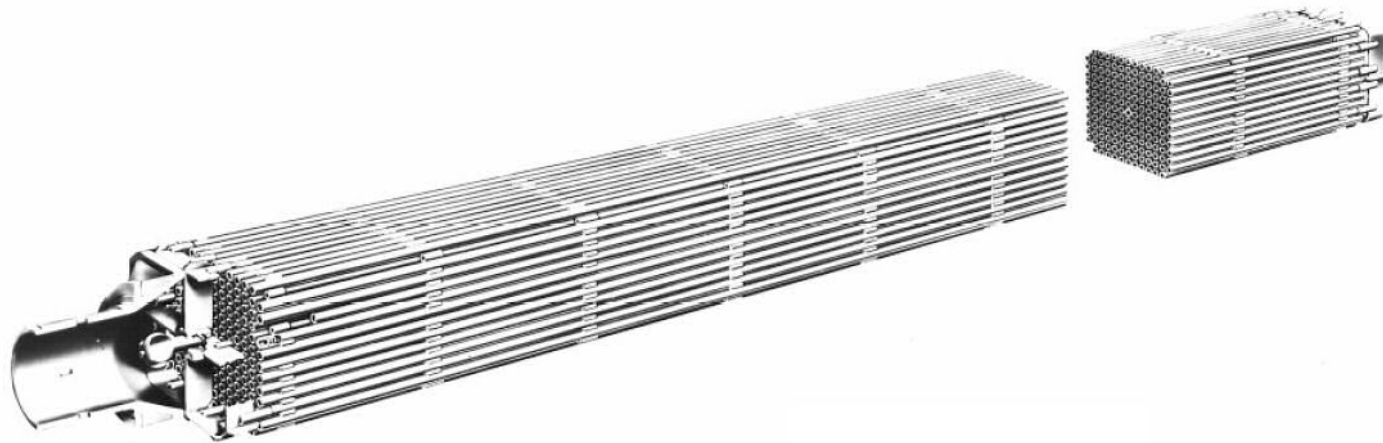

3% to 5% uranium-235 enrichment

17 by 17 approximately 12 feet long weight ~ 500 Kg U.

**Water moderated reactor fission of the uranium-235
produces heat**

Optimized to produce energy in a reactor

Used Nuclear Fuel

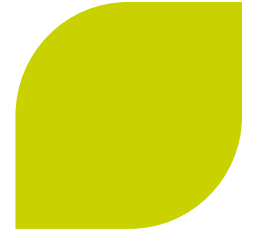

► Composition of used light water reactor fuel

- ◆ 1 LWR fuel assembly = 500 kg uranium before irradiation in the reactor

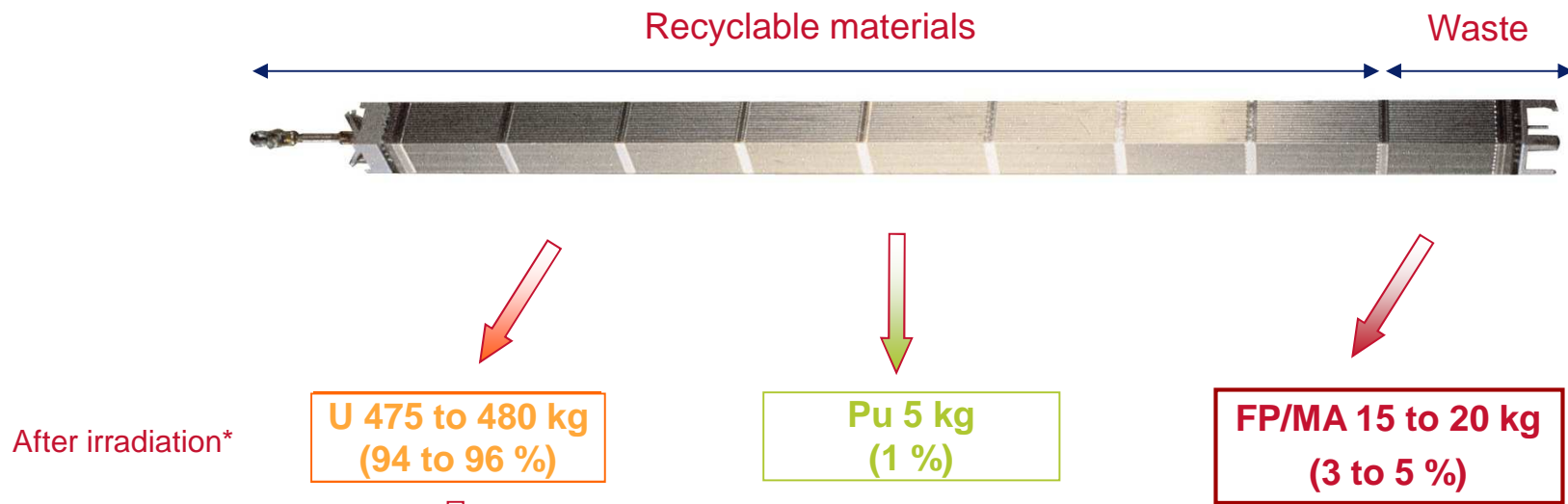

* Percentages may vary based on fuel burnup

Used Nuclear Fuel Where do we go from here?

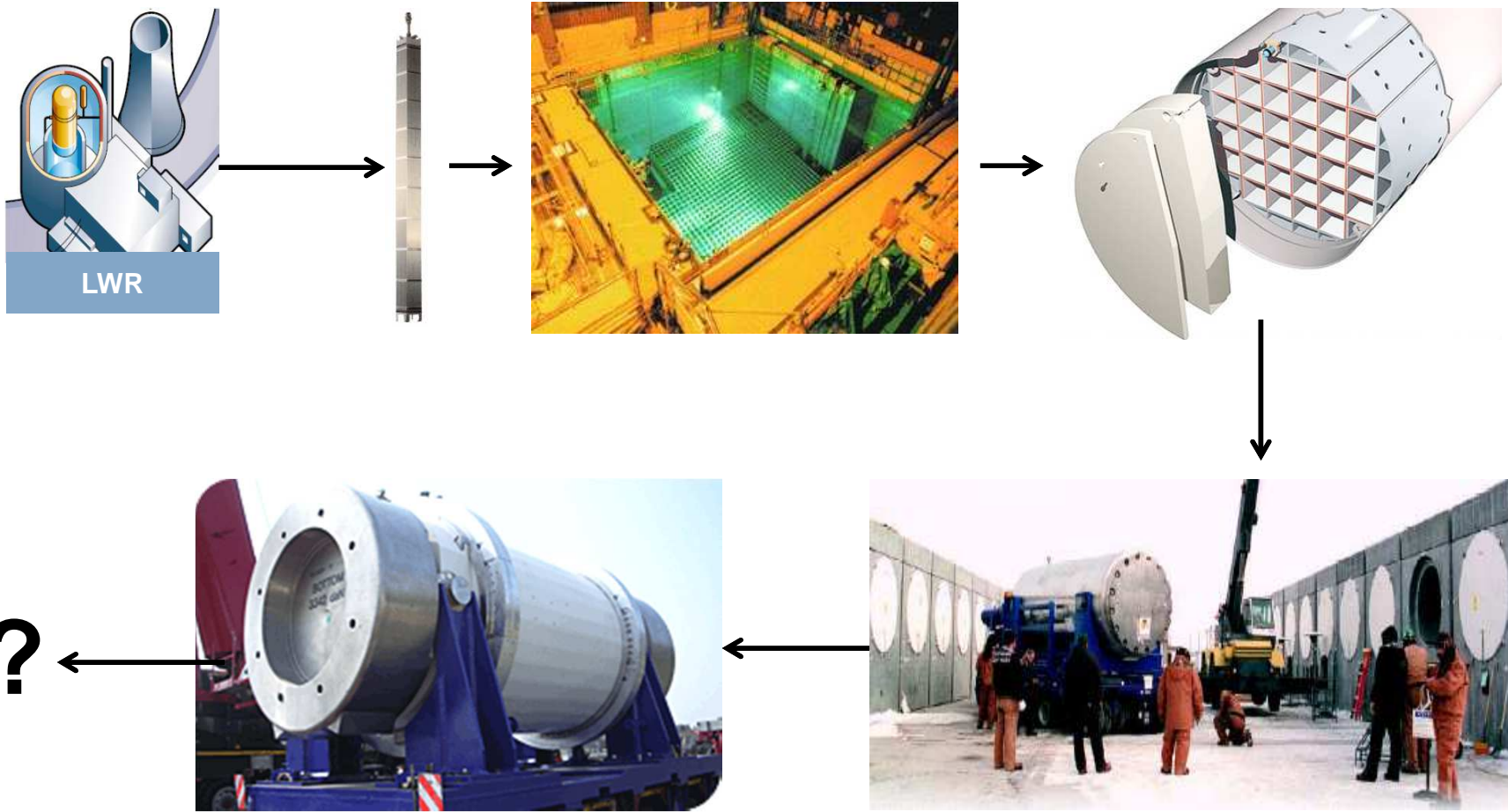

Important to keep options open



Used Nuclear Fuel

- ▶ US reactors currently discharge > 2,000 tUNF/y with a total inventory of >65,000 tUNF stored at reactor sites around the country.

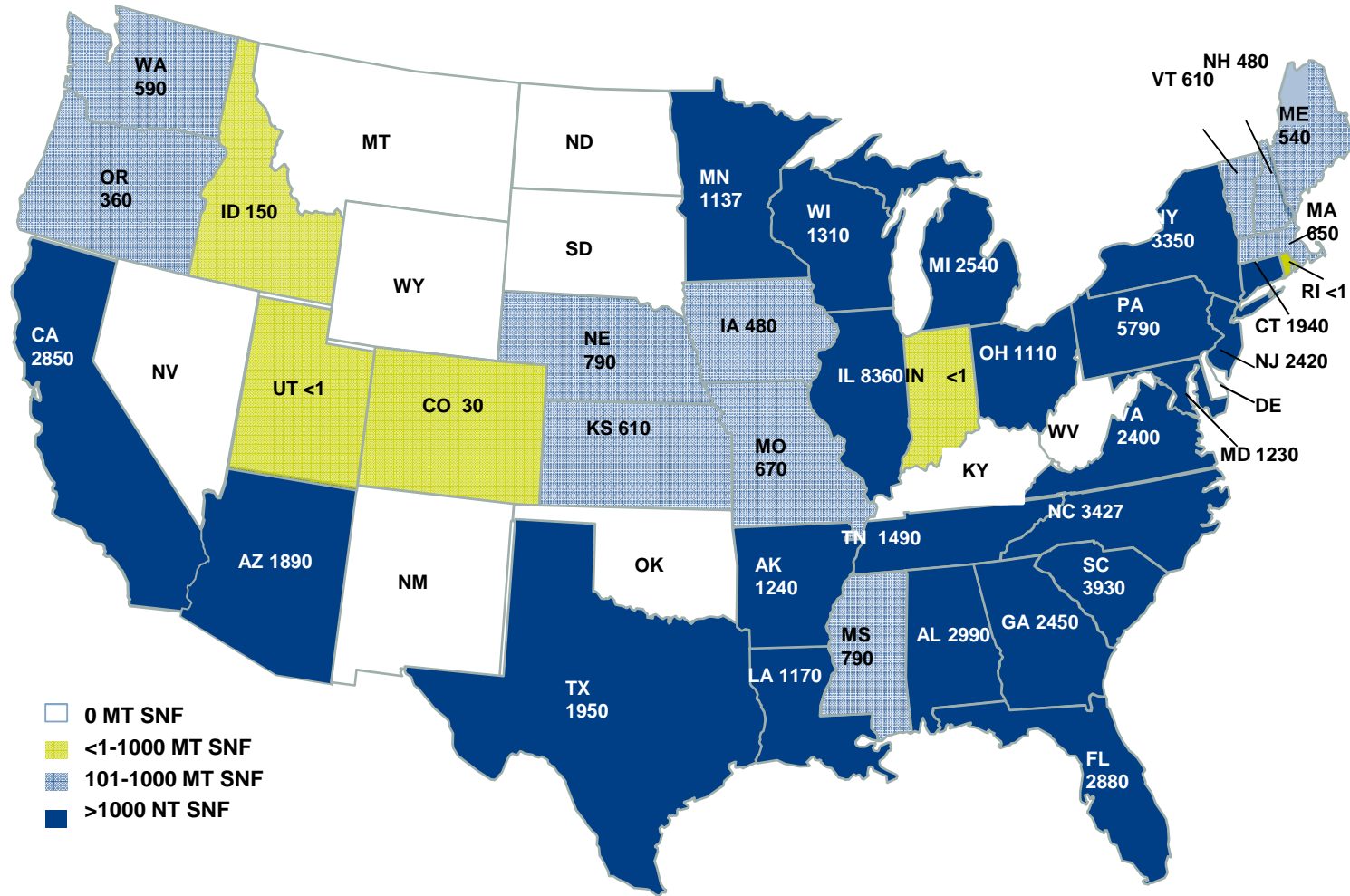

Number of Fuel Assemblies



Year	Assemblies			Per Year
	Dry Storage	In Pool	Total	
2009	39,460	177,397	216,857	
2010	44,552	179,894	224,446	7,589
2011	49,951	182,448	232,399	7,953
2012	54,946	184,701	239,647	7,248
2013	60,986	186,159	247,145	7,498

Taken from paper:-Fuel cycle potential waste disposition FCR&D-USED 2010-000031





Burn-up of US Assemblies

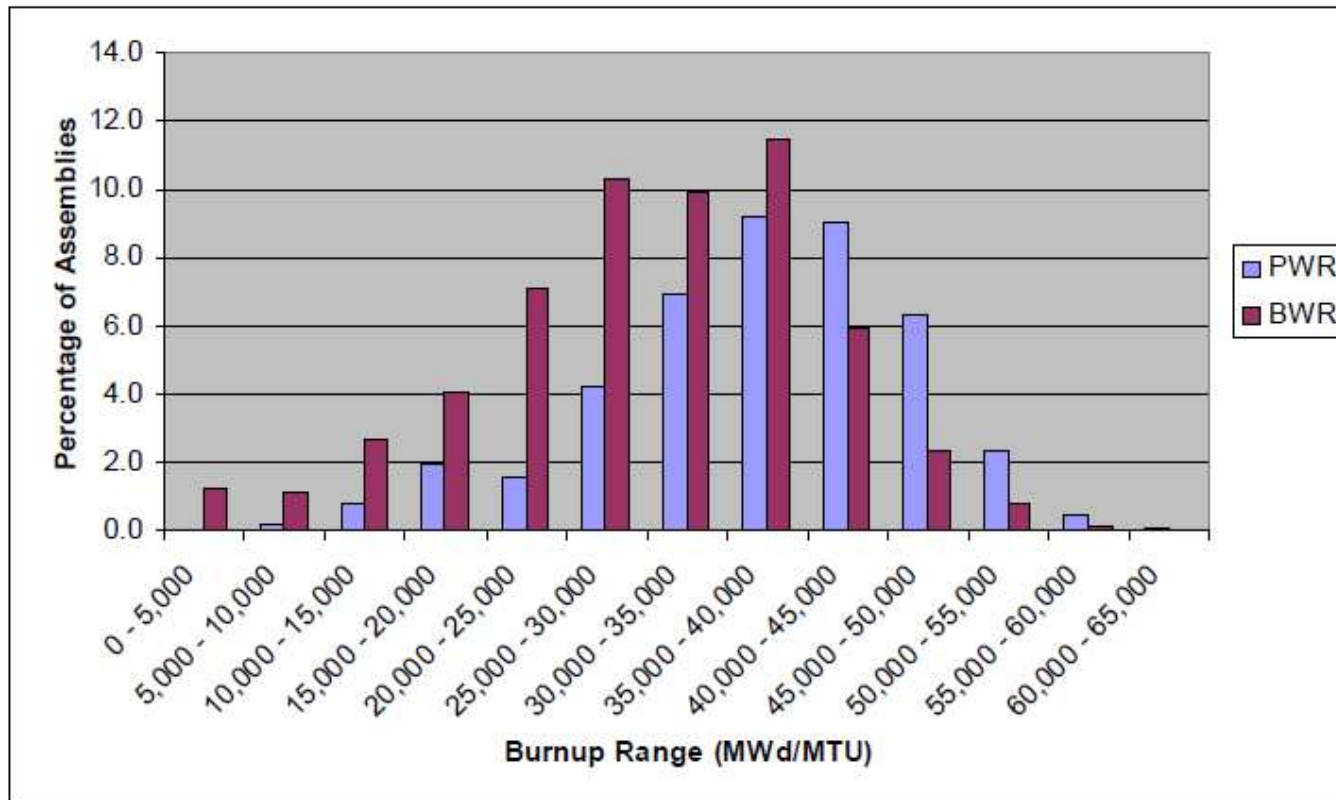

US has a unique inventory of UNF allowing consideration of different options compared to other countries

Taken from paper:-Fuel cycle potential waste disposition FCR&D-USED 2010-000031

Background Used Nuclear Fuel is Located in 4 Regions

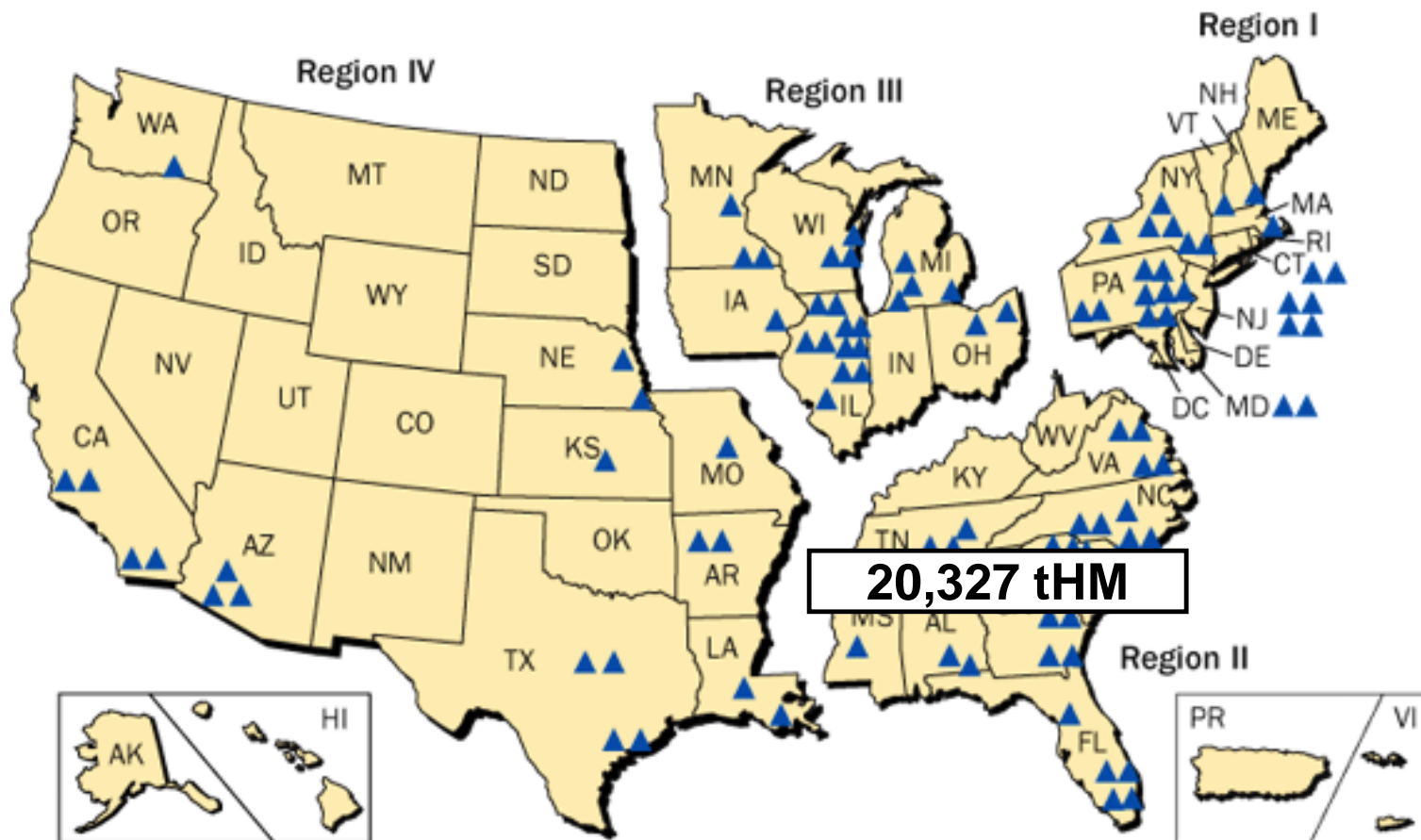

Total Current US UNF : ~65,000 tHM/y

www.nrc.gov
www.nei.org



SE Region: South East Nuclear “Industry”

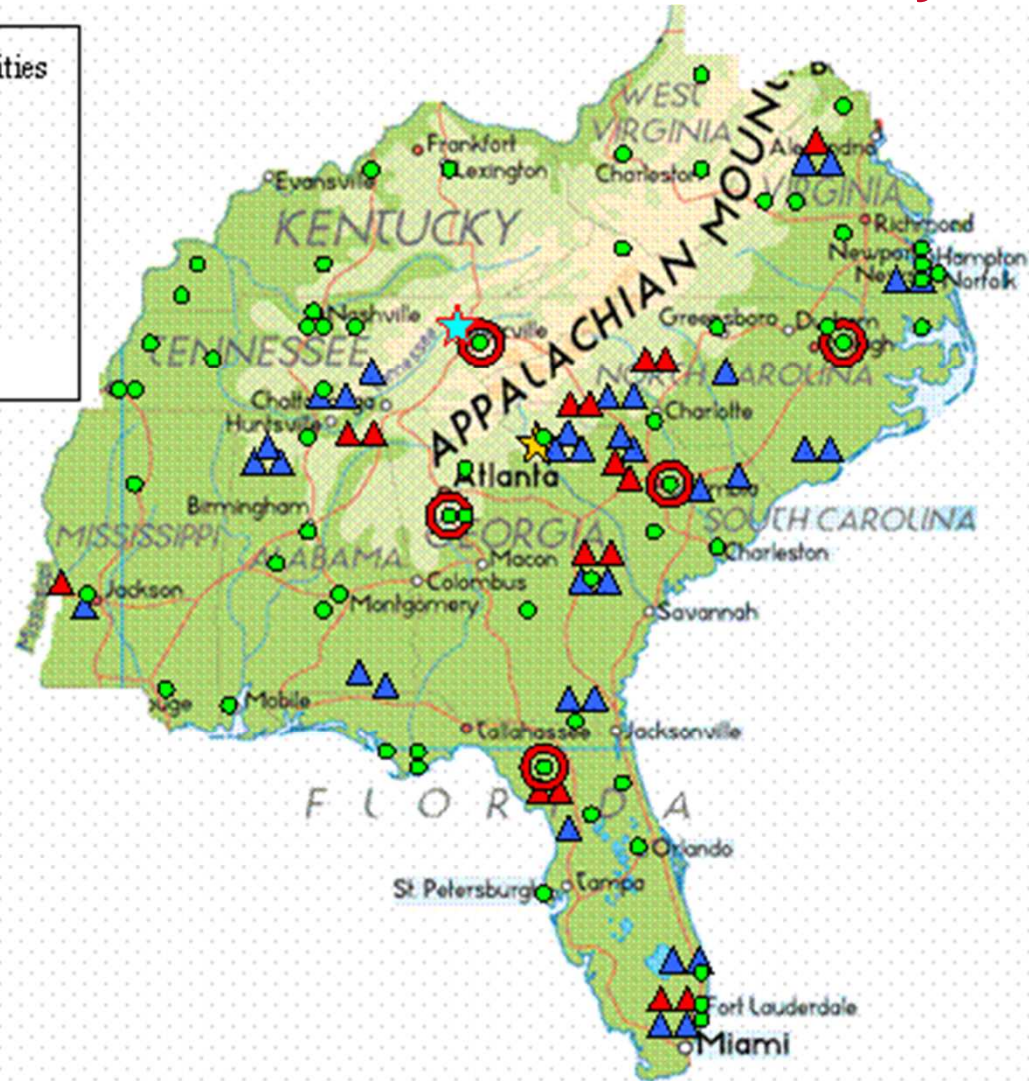
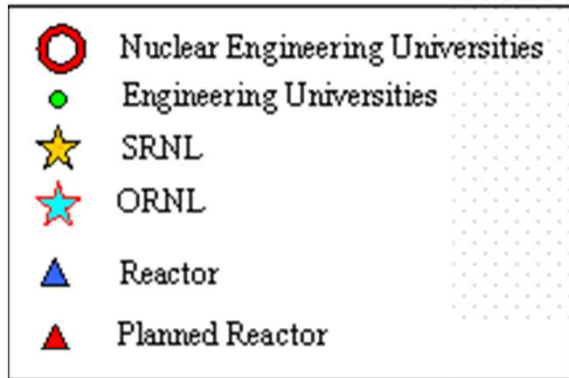

Integrated UNF Management Site – Dry Storage Pad



Phased Approach – leaves options open

Integrated UNF Management Site – Dry Storage, UNF Unloading Facility, Storage Pool

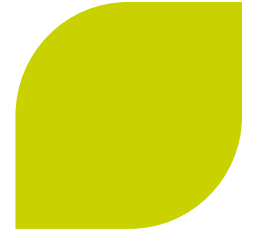

Hot Cell



La Hague Hot Cell
copyright: AREVA /
JEZEQUEL SIDNEY

Storage Pool



Keeping Options Open



- ▶ **Not all or nothing concept; we have options.**
- ▶ **Move some fuel to one interim storage site.**
- ▶ **Move some fuel to regional interim storage sites.**
- ▶ **Repackage some of the fuel and dispose of in geological repository.**
- ▶ **Size reduce some of the fuel assemblies and dispose of in a geological repository.**
- ▶ **Recycle some of the fuel and dispose of engineered waste form in geological repository.**
- ▶ **Recycle some of the fuel and develop advanced fuel cycle.**

Integrated UNF Management Site- Pilot Recycling Facility



***Evolutionary technology benefiting from over 40
years of operating experience.***

***Most of these facilities are already found on the
Savannah River Site.***

Initial Pilot Facility



- ▶ **Balanced fuel cycle**
 - ◆ Recycling capacity matched to product demand
- ▶ **Propose an initial “*Pilot*” 800 tHM/y capacity plant that builds on best available technology to minimize risk**
- ▶ **COEX™ Separations process so “NO” separated Pu**
- ▶ **Manage product using existing nuclear infrastructure while DOE develops Gen IV Reactor (50 plus years for first commercial Unit)**
- ▶ **LWR MOX is therefore an “*interim*” step for closing the cycle**
- ▶ **Pilot Facility could supply fuel to:**
 - ◆ Limited number of existing LWR’s
 - ◆ ~4 Gen III+ reactors
 - ◆ 500 MWe SFR’s

Classic Recycling of UNF

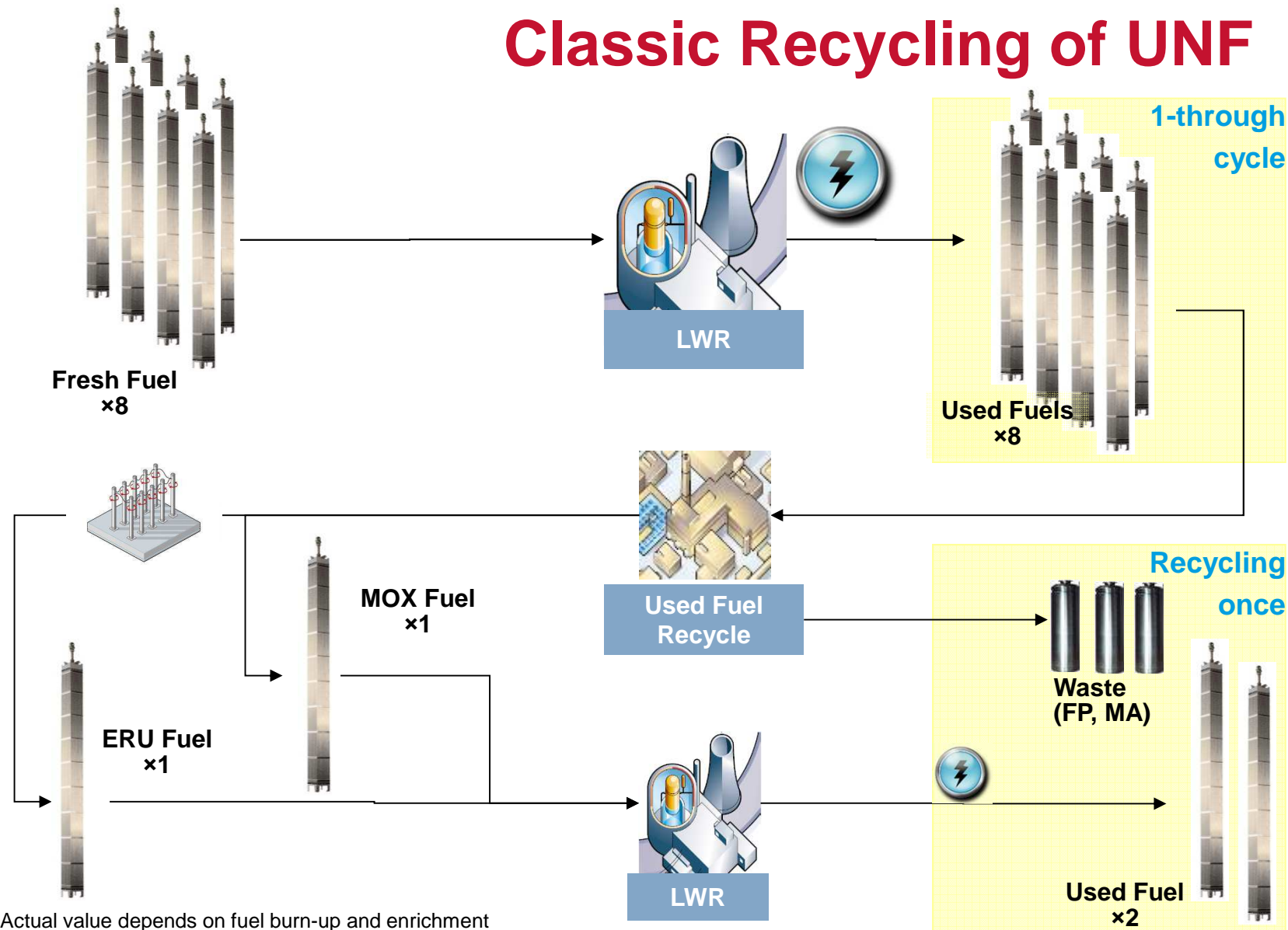

•Actual value depends on fuel burn-up and enrichment

Lifting UNF to Cropping Machine

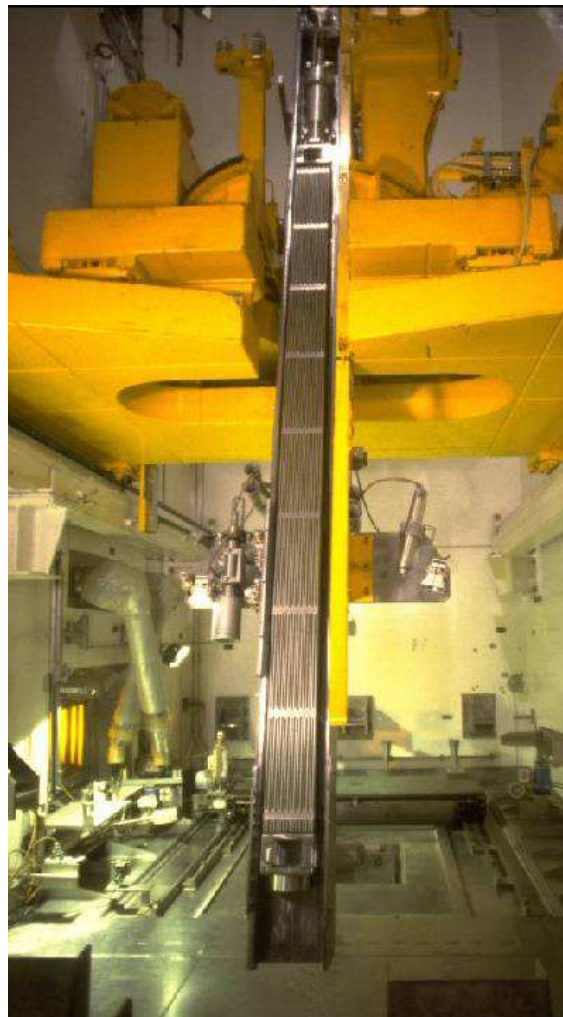

Mechanical Shearing

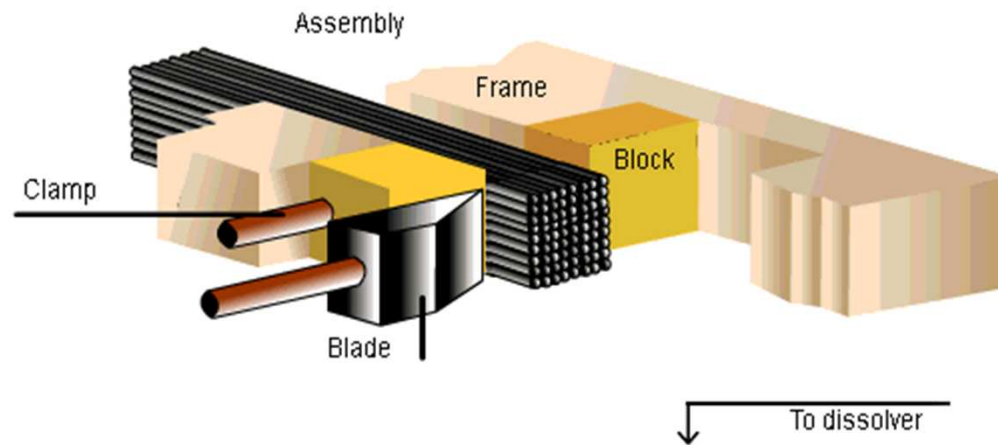

Rotary Dissolver

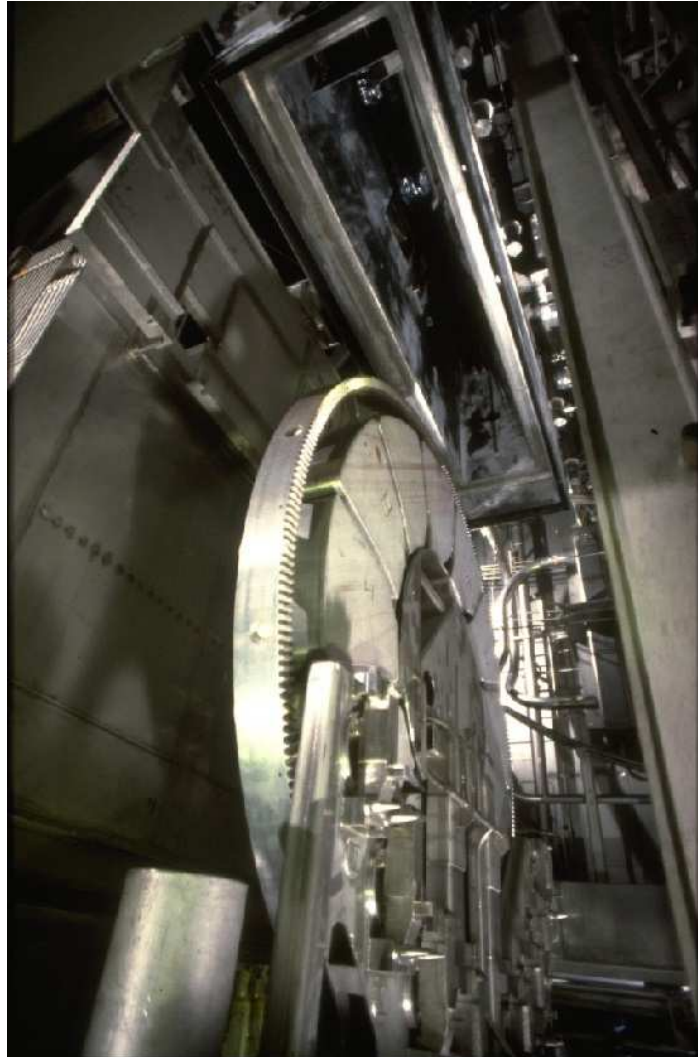

Dissolution

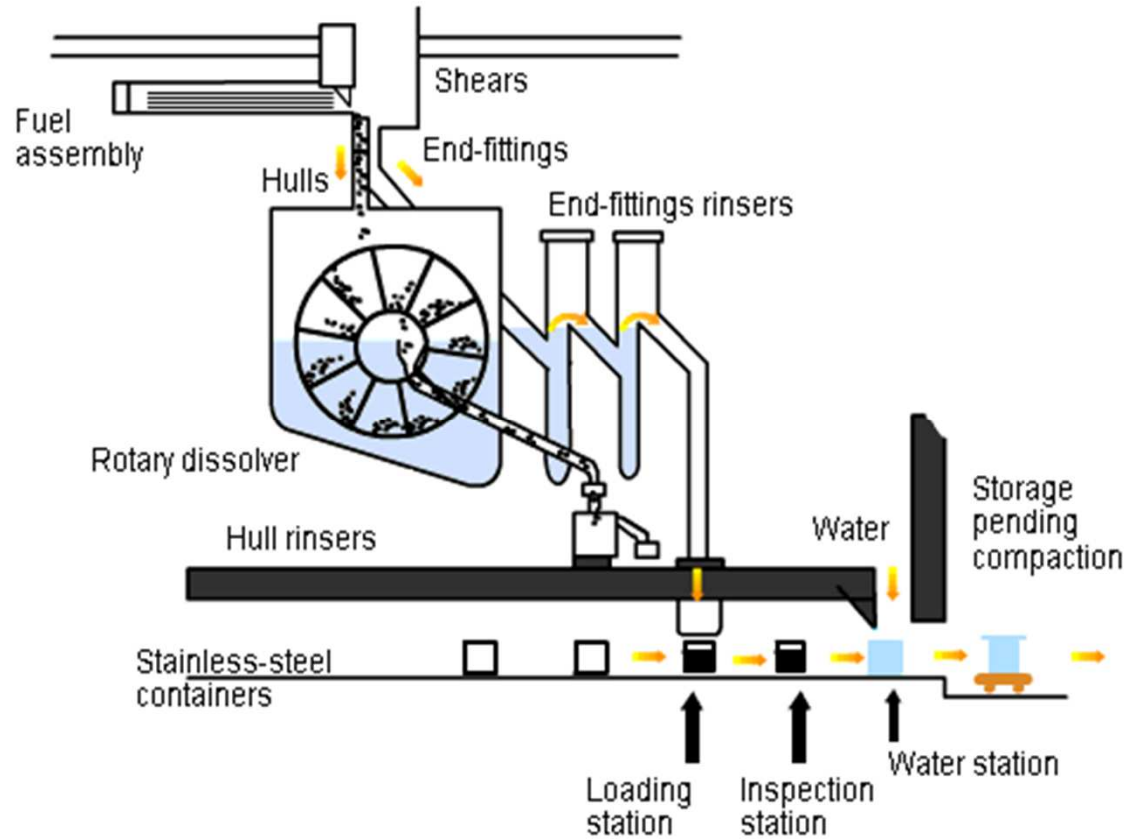
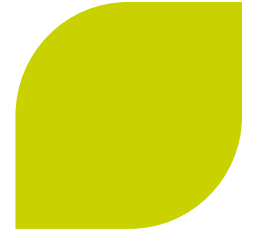

Vitrification Test Platform



VITRIFICATION Pouring glass to immobilize radioactive waste.



Engineered Waste Form

Continuous Volume Reduction Over Time Operational Experience AREVA

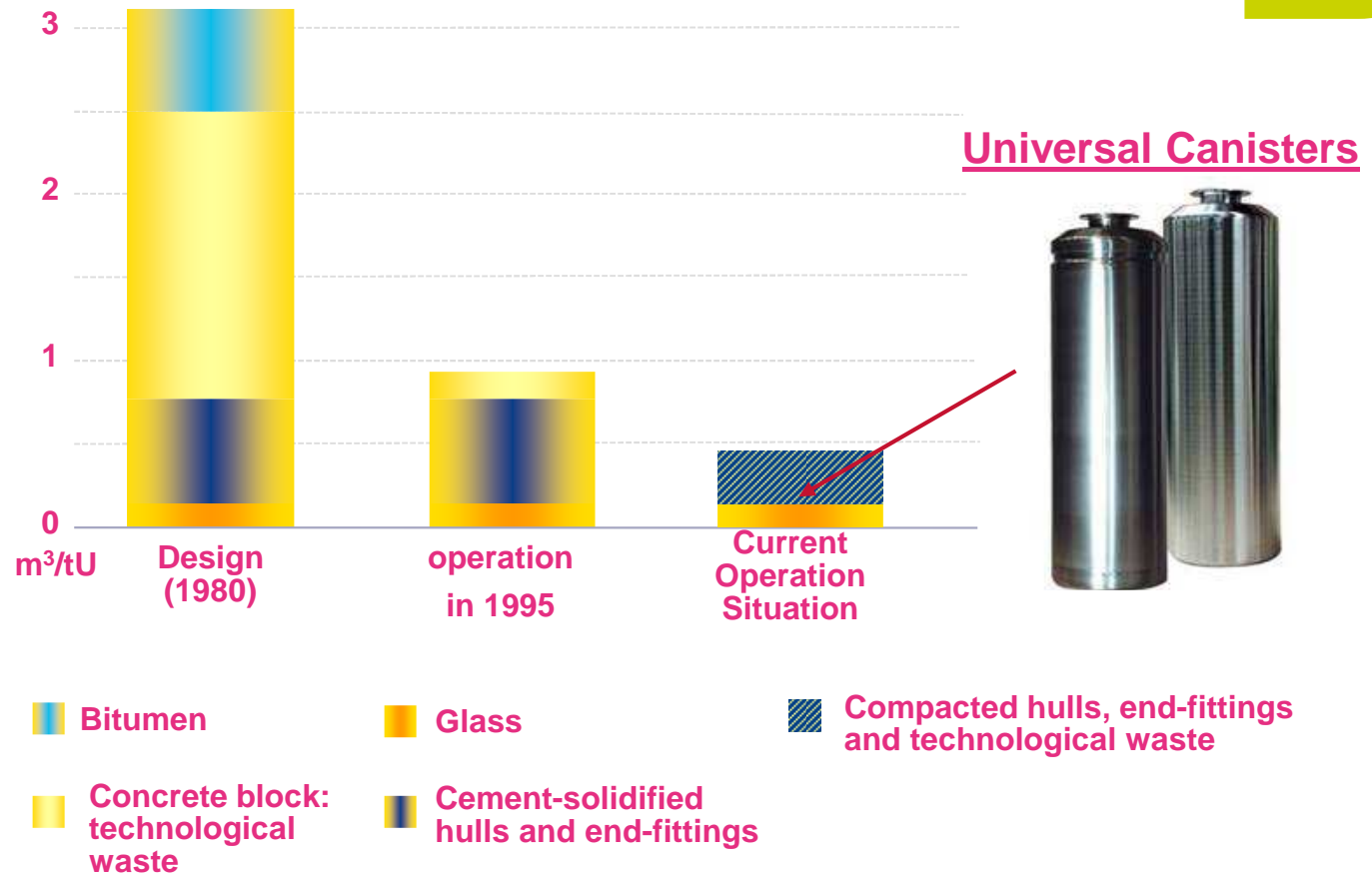

Continuous Improvement

Wastes Volumes from Recycling in France

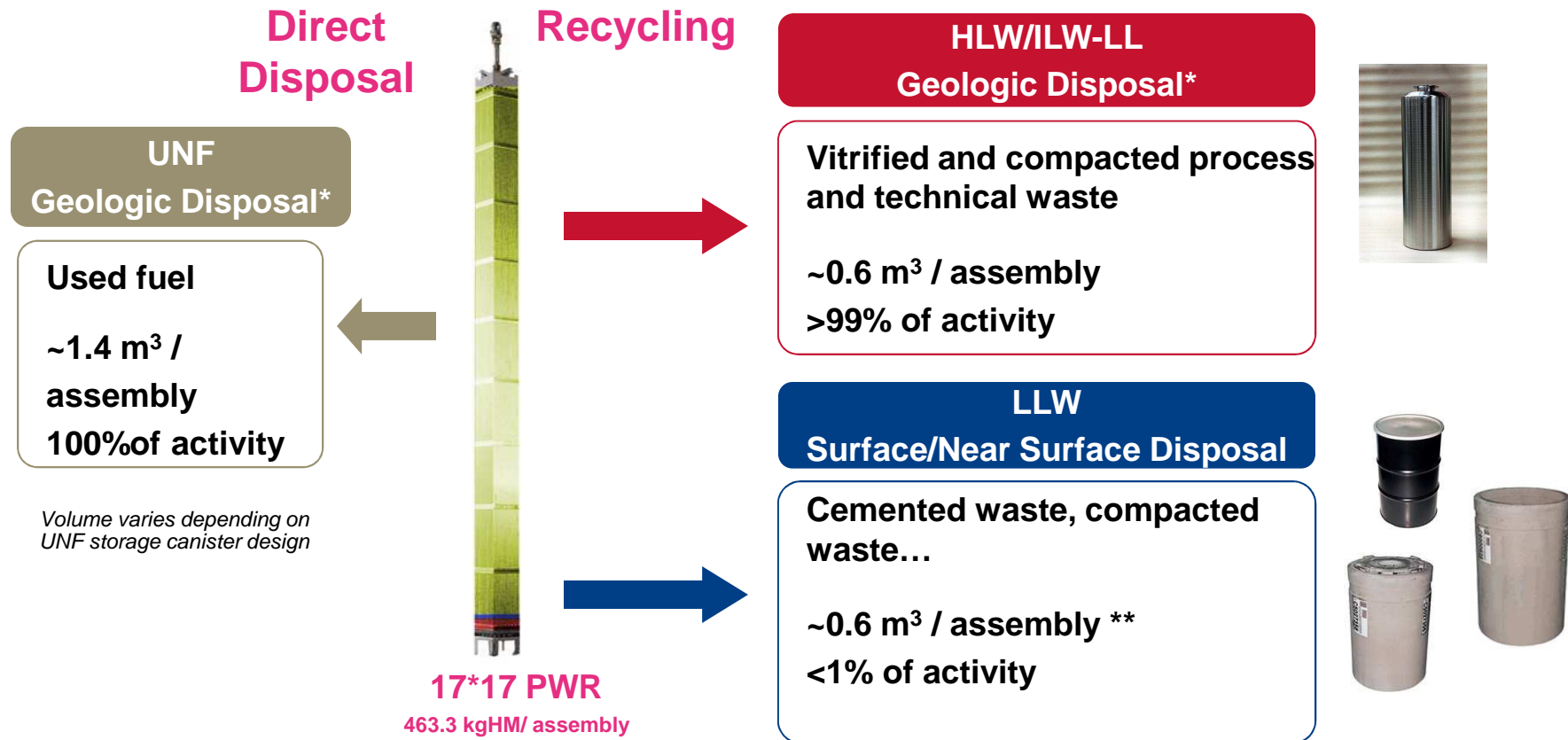

Based on operational data from La Hague and MELOX reference plants and ANDRA disposal studies

* Volumes for UNF and for wastes requiring geologic disposal includes the volume of the waste disposal packages

**Waste generated by an 1000 tHM/yr recycling plant using current technology (La Hague and MELOX reference plants)

Work Force Directly Employed (800 MT/y plant)

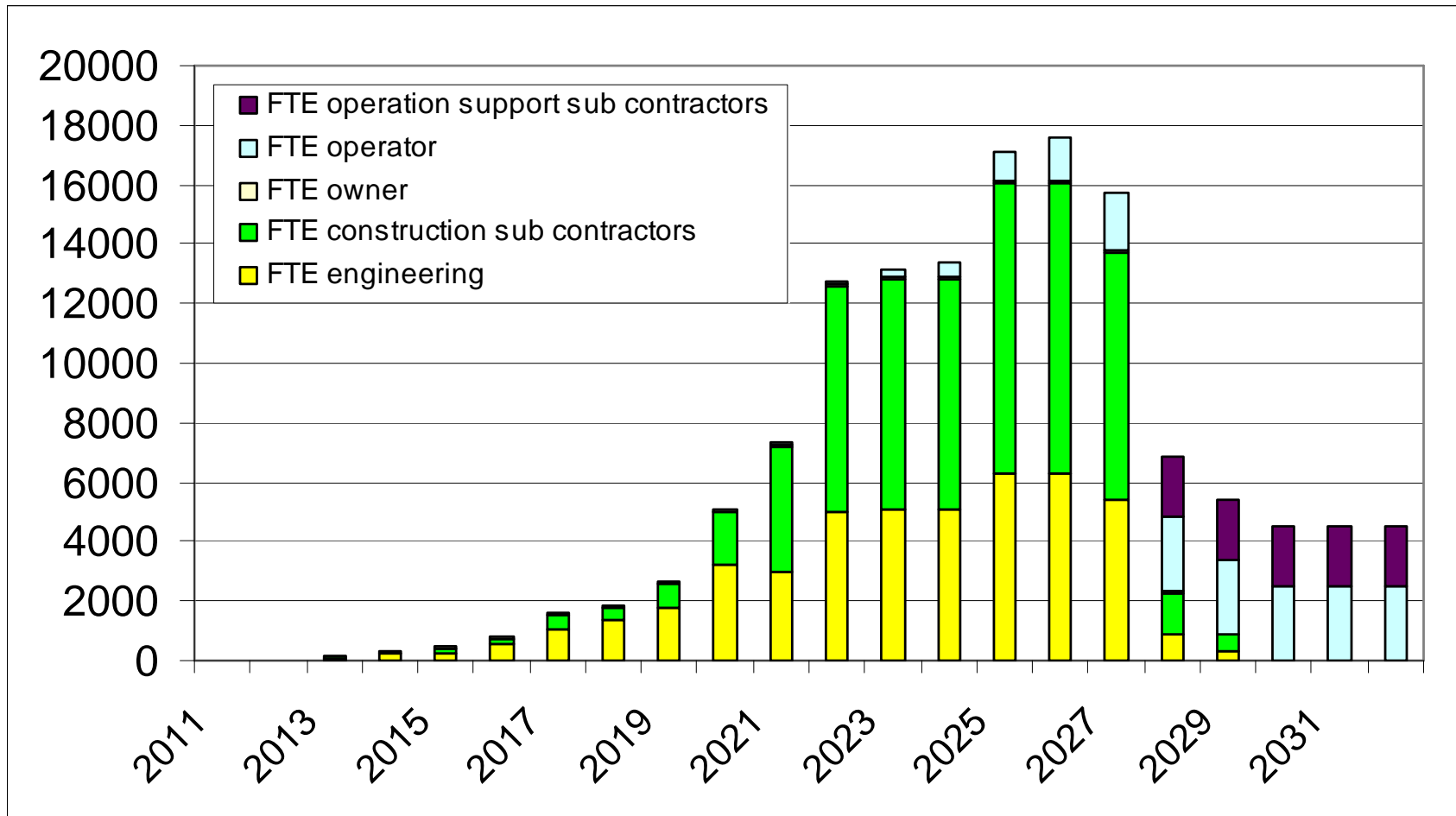

Major Impact on Region from Primary and Secondary Jobs

Integrated UNF Management Site-Advanced Separations and Fuel Fabrication

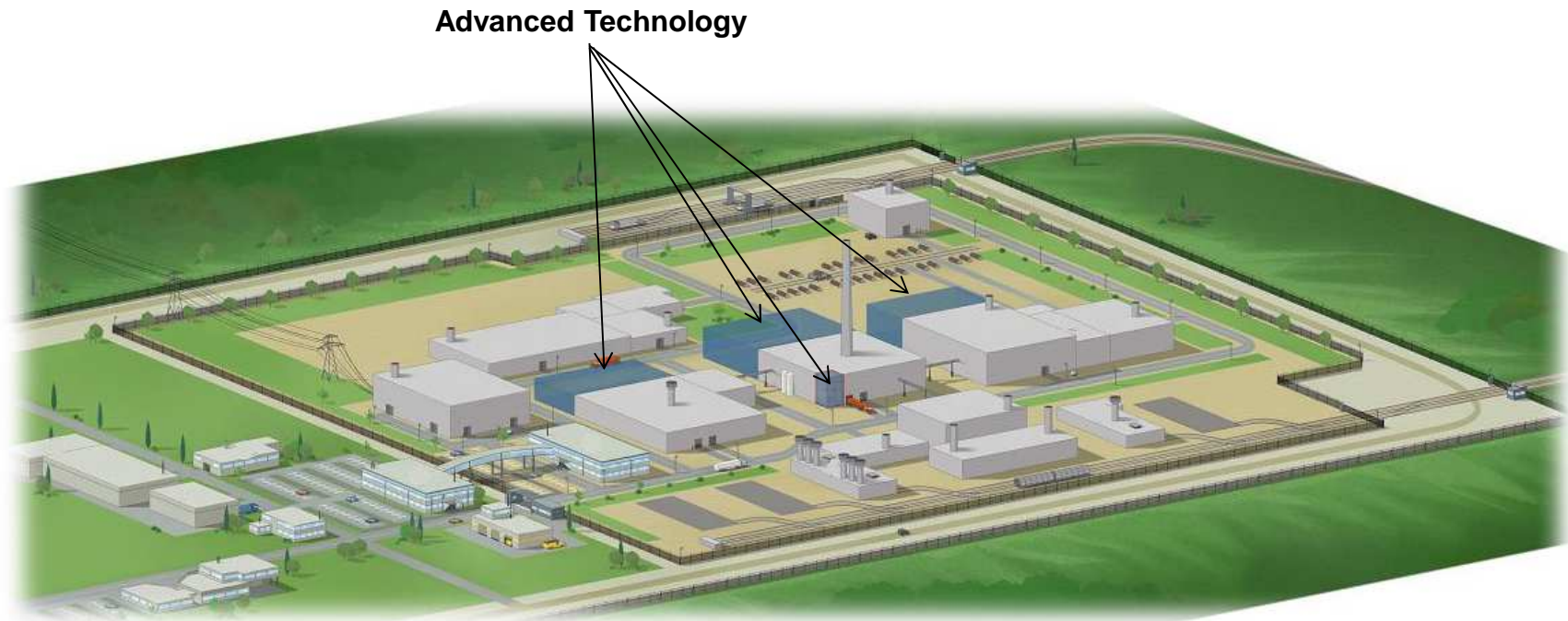

Advanced separations and transmutation fuel production are an addition to the pilot facility, not a replacement

Conclusions

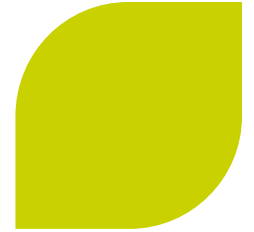

- ▶ **US is unique due to the large inventory of UNF we have.**
- ▶ **US has specific regulations that will influence the fuel cycle.**
- ▶ **Options are important and should be considered.**
- ▶ **Recycling:**
 - ◆ **Is economically viable compared to direct disposal.**
 - ◆ **Reduces volume of HLW requiring geological disposal.**
 - ◆ **Produces an engineered waste form for geological HLW.**
 - ◆ **Recycle of MOX is viable in the US.**
- ▶ **Phased approach is proposed.**
 - ◆ **Do not commit the country 100% to any one technology.**
 - ◆ **Can be adapted and upgraded with new technology.**
- ▶ **Must develop a simple business case for any future fuel cycle.**
- ▶ **Final geological repository will influence fuel cycle deployment.**